

(8182)63-90-72
+7(7172)727-132
(4722)40-23-64
(4832)59-03-52
(423)249-28-31
(844)278-03-48
(8172)26-41-59
(473)204-51-73
(343)384-55-89
(4932)77-34-06
(3412)26-03-58
(843)206-01-48

(4012)72-03-81
(4842)92-23-67
(3842)65-04-62
(8332)68-02-04
(861)203-40-90
(391)204-63-61
(4712)77-13-04
(4742)52-20-81
(3519)55-03-13
(495)268-04-70
(8152)59-64-93
(8552)20-53-41

(831)429-08-12
(3843)20-46-81
(383)227-86-73
(4862)44-53-42
(3532)37-68-04
(8412)22-31-16
(342)205-81-47
- - (863)308-18-15
(4912)46-61-64
(846)206-03-16
- (812)309-46-40
(845)249-38-78

(4812)29-41-54
(862)225-72-31
(8652)20-65-13
(4822)63-31-35
(3822)98-41-53
(4872)74-02-29
(3452)66-21-18
(8422)24-23-59
(347)229-48-12
(351)202-03-61
(8202)49-02-64
(4852)69-52-93

: www.rzhev.nt-rt.ru ||

: rvz@nt-rt.ru

(F) 400

:

412-4/24,

IM2008

:

1.
2.

1.

183-74: S3 - 40%

2.1
2.2

: S3 - 15%, 25%, 60%; S2 - 30 60 .

:

- S3 - 25%,

- S3 - 15%

3.
4.

20459-87: ICO141

: - IP44,

- IP54

- IP20.

5.
6.
7.
8.
9.
10.

16372-84: 1.

: 2,8 /

8865-87: F (155°C) H (180°C).

2.

3351-066-5036973-00.

F - 2,5 , H - 3

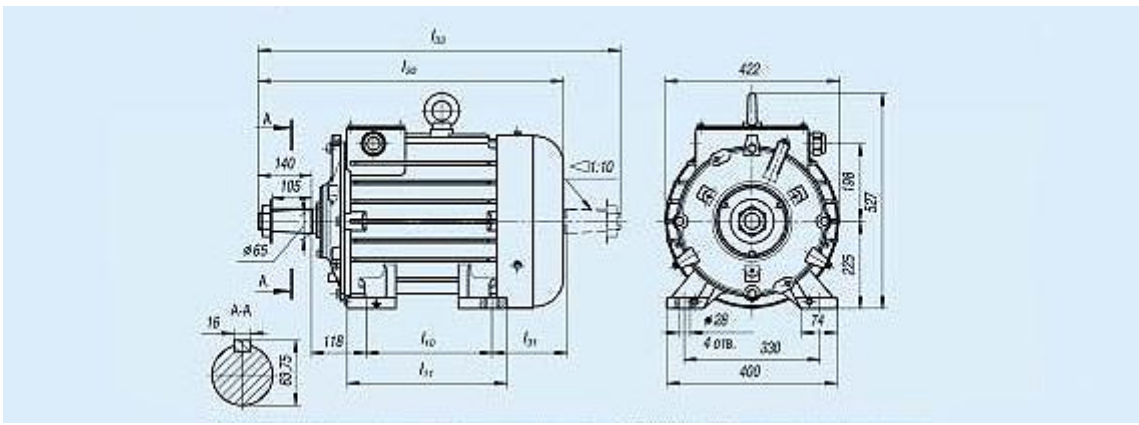

1. 1004 (IM 1001-1 -)

(F) 400

IM1003, 1003-1,

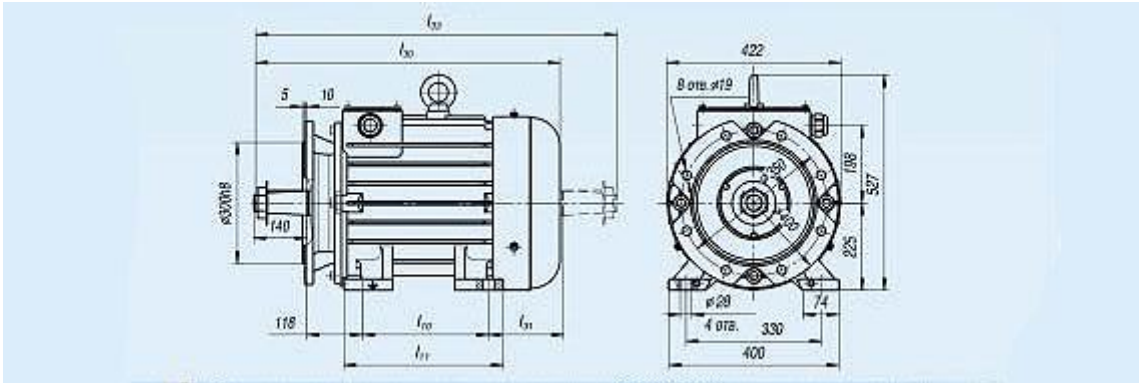

2. 1. 1.

(F) 400

IM2003, 2004.

					%	Cos		, %		
MTKH 411-6	H	6	22	935	82,5	0,79	2,8	6,5	380/220	51,0/88,1
MTKF 411-6	F		22	935	82,5	0,79	2,8	6,5	380/220	51,0/88,1
MTKH 412-6	H		30	935	83,5	0,78	2,8	6,5	380/220	70,0/120,9
MTKF 412-6	F		30	935	83,5	0,78	2,8	6,5	380/220	70,0/120,9
MTKH 411-8	H	8	15	695	80	0,71	2,8	7,3	380/220	40,0/69,1
MTKF 411-8	F		15	695	80	0,71	2,8	7,3	380/220	40,0/69,1
MTKH 412-8	H		22	700	80,5	0,69	2,8	6,7	380/220	60,0/103,6
MTKF 412-8	F		22	700	80,5	0,69	2,8	6,7	380/220	60,0/103,6
MTKH 411-4/24	H	4	30	1375	87	0,92	2,8	8,3	380/220	63/109
		24	1,5	170	63,5	0,64	2,8	32	380/220	135/234

2.

MT H(F) 400

		l_{10}	l_{11}	l_{30}	l_{31}	l_{33}	
MTKH(F) 411-6 MTKF(F) 411-8	IM1003	335	400	749	175	-	235
	IM1003-1	335	400	742	175	-	235
	IM1004	335	400	749	175	898	240
	IM2003	335	400	749	175	-	249
	IM2004	335	400	749	175	898	255
	IM2008	335	480	749	175	905	262
MTKH(F) 412-6 MTKF(F) 412-8	IM1003	420	480	824	165	-	292
	IM1003	420	480	817	165	-	292
	IM1004	420	480	824	165	973	297
	IM2003	420	480	824	165	-	306

	IM2004	420	480	824	165	973	312
	IM2008	420	480	824	165	980	320
MTKH 412-4/24	IM2003	420	420	824	165	980	330

:

(8182)63-90-72
+7(7172)727-132
(4722)40-23-64
(4832)59-03-52
(423)249-28-31
(844)278-03-48
(8172)26-41-59
(473)204-51-73
(343)384-55-89
(4932)77-34-06
(3412)26-03-58
(843)206-01-48

(4012)72-03-81
(4842)92-23-67
(3842)65-04-62
(8332)68-02-04
(861)203-40-90
(391)204-63-61
(4712)77-13-04
(4742)52-20-81
(3519)55-03-13
(495)268-04-70
(8152)59-64-93
(8552)20-53-41

(831)429-08-12
(3843)20-46-81
(383)227-86-73
(4862)44-53-42
(3532)37-68-04
(8412)22-31-16
(342)205-81-47
- - (863)308-18-15
(4912)46-61-64
(846)206-03-16
- (812)309-46-40
(845)249-38-78

(4812)29-41-54
(862)225-72-31
(8652)20-65-13
(4822)63-31-35
(3822)98-41-53
(4872)74-02-29
(3452)66-21-18
(8422)24-23-59
(347)229-48-12
(351)202-03-61
(8202)49-02-64
(4852)69-52-93

: www.rzhev.nt-rt.ru ||

: rvz@nt-rt.ru